

EAX® SERIES

EAX-2500

9VDC Battery Powered Wall Mount Exit Alarm (Optional AC/DC External Power)

The Detex EAX-2500 Series Exit Alarm is designed for applications requiring a 9VDC battery or external AC/DC powered alarmed exit device on secured doors. The alarm, with approximately 100dB, will sound when an unauthorized exit occurs. The smaller size of the EAX-2500, which is designed to fit in a standard 4"x4" outlet box, makes it the choice for quick and easy installations on emergency exit and restricted doors.

Shown with cylinder (mortise cylinder sold separately)



Benefits -

- Field selectable features allow customer to choose status indicators and auto rearm options
- 100dB piezo horn provides security for restricted doors
- Easy to install using ordinary tools to save time and money
- New graphics on cover are easy to understand and make key operation simple
- Available in either gray or black to blend with any décor

Features -

- Surface and flush mount available using 4"x4" double switch/outlet box
- Patented cam assembly automatically adjusts for different size cylinders without spacers
- Inside Key Control uses mortise cylinder with standard Yale cam
- Improved electronic circuits for longer battery life, LED functions
- 9VDC battery powered with optional AC/DC external power
- Low battery alert is field selectable if using AC power
- Tamper resistant housing and cover protects electronics and battery from manipulation
- Extended bypass allows alarm to remain silenced when door is open and automatically rearm upon closing of door

Mechanical Options -

- KS - Key Stop (Key removed only when armed)
- EAX-2500 Flush or Surface
- EAX-2500FK - Complete kit contains alarm, warning sign, flush back box, flush magnetic switch and 24VAC transformer
- EAX-2500SK - Complete kit contains alarm, warning sign, surface back box, surface magnetic switch and 24VAC transformer

Electrical Options -

Other EAX Exit Alarms Include:

- EAX-500 - Battery Powered
- EAX-500W - Weatherized Battery Powered
- EAX-3500 - Timed Bypass and Rechargeable Battery

Accessories -

- IC7 - Interchangeable mortise cylinder (can be factory installed)
- MC65 - Mortise cylinder (can be factory installed)

Technical Information -

- Machine and Self Drilling Screws (Std.)
- Optional Sex Nuts or Security Torx Screws available

Dimensions -

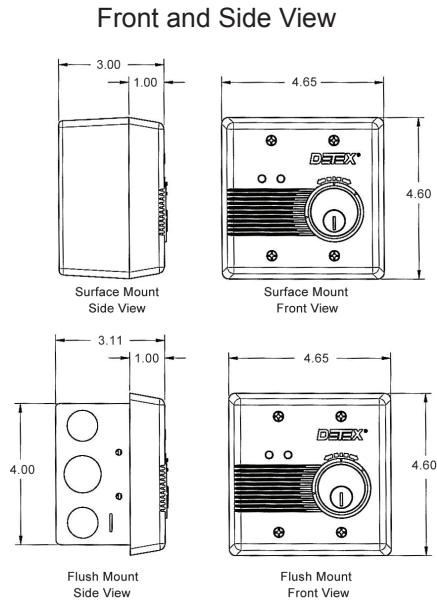

Riser Diagram

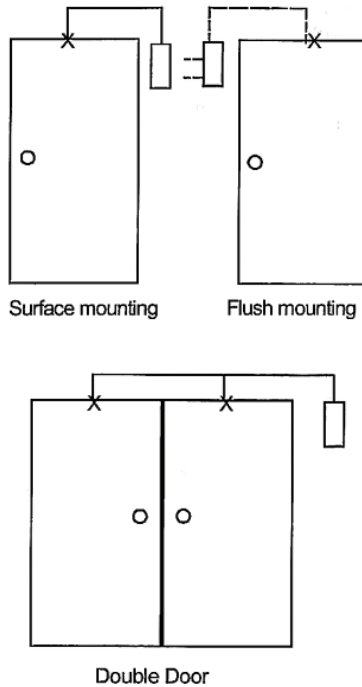

Detex Limited Warranty

3 Year Limited Manufacturer's Warranty

Double door application as shown above available with EAX-500, EAX-2500 and EAX-3500.

Note: Double door application as shown above **not** available with EAX-500W weatherized alarm.



Detex Corporation
 302 Detex Drive
 New Braunfels, Texas 78130-3045 USA
 PH. (830) 629-2900
 (800) 729-3839
 FAX (830) 620-6711
 (800) 653-3839
<http://www.detex.com>
 USA Sales:
marketing@detex.com
 International Sales:
export@detex.com